

Billing



Boats®

YMER 244*

PHOTO MANUAL



DK YMER

Baseret på en dansk slæbebåd M/S YMER, bygget i 1942 i Aalborg, for Forenede Buggerselskab. I 1951 kæntrede Ymer i Frihavn, og den 4 mand store besætning blev reddet. Det blev senere bjærget, og i 1975 blev det solgt til et græsk firma og omdøbt til Δeka (Deka).

GB YMER

Based on a danish tugboat M/S YMER, build in 1942 in Aalborg, for the "Forenede Buggerselskab". In 1951 the Ymer capsized in Copenhagen "Frihavn", and the 4 man crew were saved. It was later salvage and in 1975 it was sold to a Greek company and rename to Δeka (Deka).

D YMER

Basierend auf einem dänischen Schlepper M/S YMER, gebaut 1942 in Aalborg, für die „Forenede Buggerselskab“. 1951 kenterte die Ymer im Kopenhagener „Frihavn“ und die vierköpfige Besatzung wurde gerettet. Später wurde es gerettet und 1975 an ein griechisches Unternehmen verkauft und in Δeka (Deka) umbenannt.

F YMER

Basé sur un remorqueur danois M/S YMER, construit en 1942 à Aalborg, pour le « Forenede Buggerselskab ». En 1951, l'Ymer chavira à Copenhague « Frihavn » et les 4 hommes d'équipage furent sauvés. Il a ensuite été récupéré et en 1975, il a été vendu à une société grecque et renommé Δeka (Deka).

NL YMER

Gebaseerd op een Deense sleepboot M/S YMER, gebouwd in 1942 in Aalborg, voor de "Forenede Buggerselskab". In 1951 kapseisde de Ymer in Kopenhagen "Frihavn", en de vierkoppige bemanning werd gered. Het werd later geborgen en in 1975 werd het verkocht aan een Grieks bedrijf en hernoemd naar Δeka (Deka).

E YMER

Basado en el remolcador danés M/S YMER, construido en 1942 en Aalborg, para el "Forenede Buggerselskab". En 1951 el Ymer zozobró en el "Frihavn" de Copenhague y los cuatro tripulantes se salvaron. Posteriormente fue rescatado y en 1975 se vendió a una empresa griega y se le cambió el nombre a Δeka (Deka).

I YMER

Basato sul rimorchiatore danese M/S YMER, costruito nel 1942 ad Aalborg, per la "Forenede Buggerselskab". Nel 1951 la Ymer si capovolve a Copenaghen "Frihavn" e i 4 membri dell'equipaggio furono salvati. Successivamente fu recuperato e nel 1975 fu venduto a una società greca e ribattezzato Δeka (Deka).

P YMER

Baseado num rebocador dinamarquês M/S YMER, construído em 1942 em Aalborg, para o "Forenede Buggerselskab". Em 1951, o Ymer virou em Copenhague "Frihavn", e a tripulação de 4 homens foi salva. Mais tarde foi resgatado e em 1975 foi vendido a uma empresa grega e renomeado para Δeka (Deka).

PL YMER

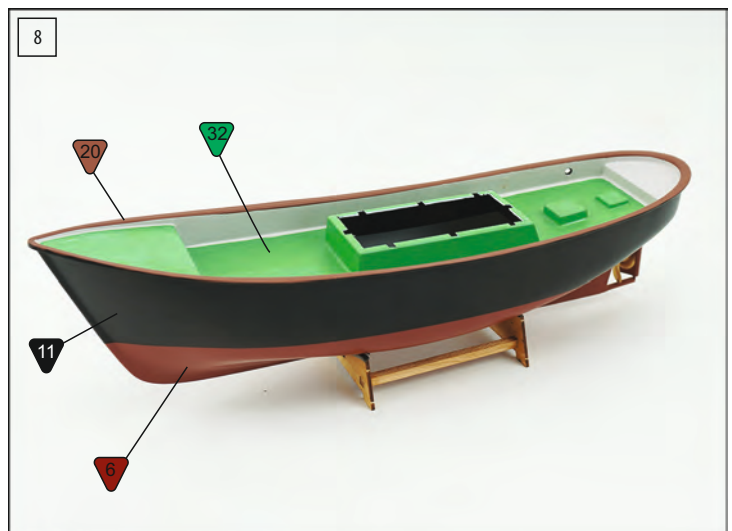
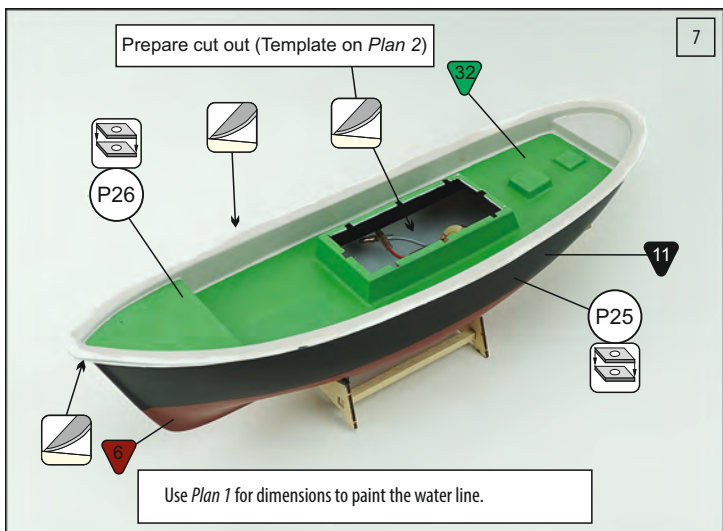
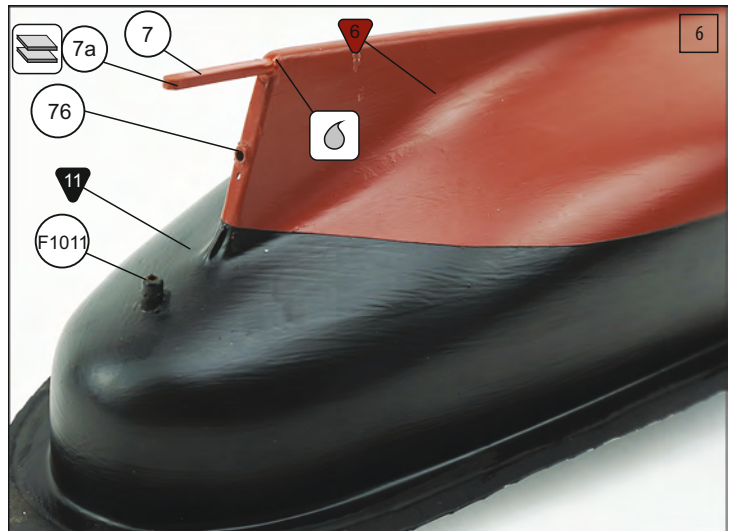
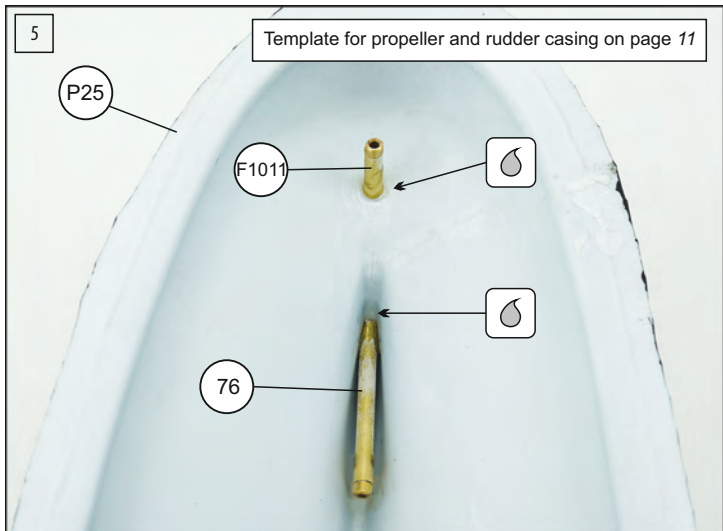
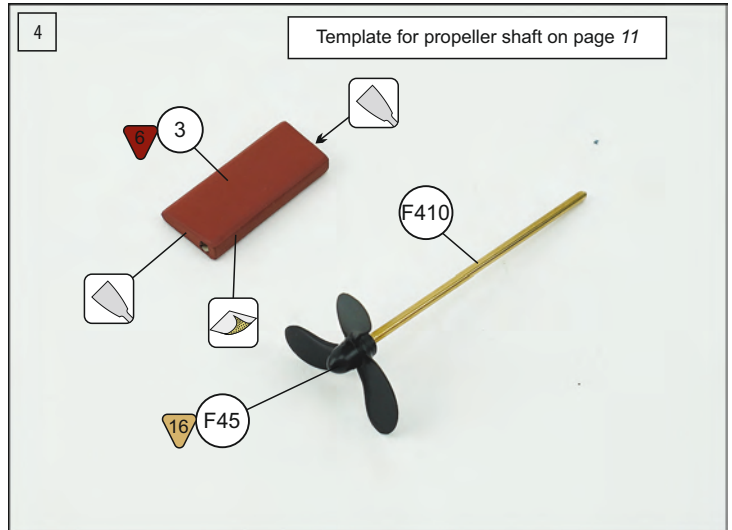
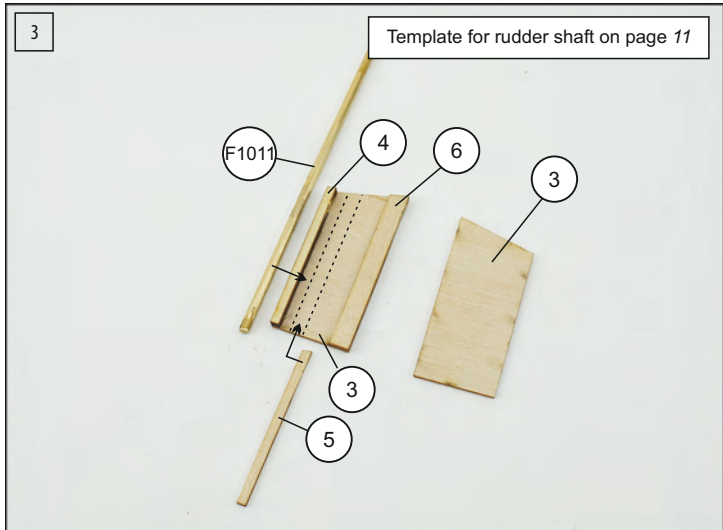
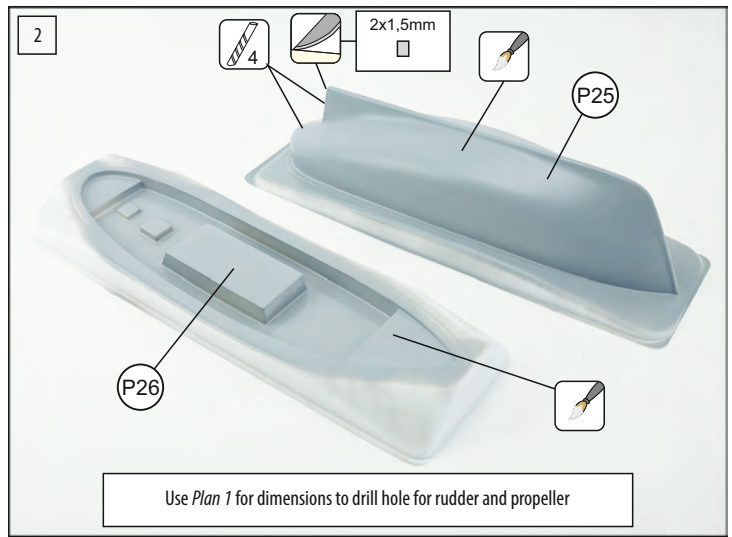
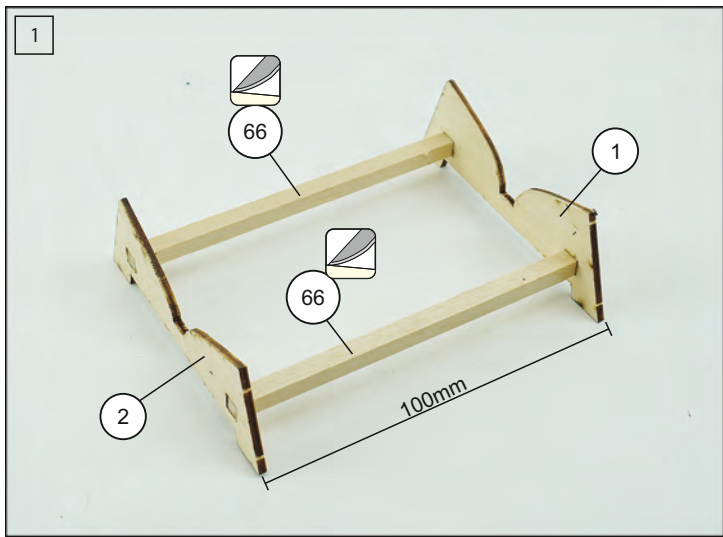
Wzorowany na duńskim holowniku M/S YMER, zbudowanym w 1942 roku w Aalborgu, dla „Forenede Buggerselskab”. W 1951 r. Ymer wyrócił się w Kopenhadze „Frihavn”, a 4-osobowa załoga została uratowana. Później udało się go uratować i w 1975 roku sprzedano go greckiej firmie i zmieniono nazwę na Δeka (Deka).

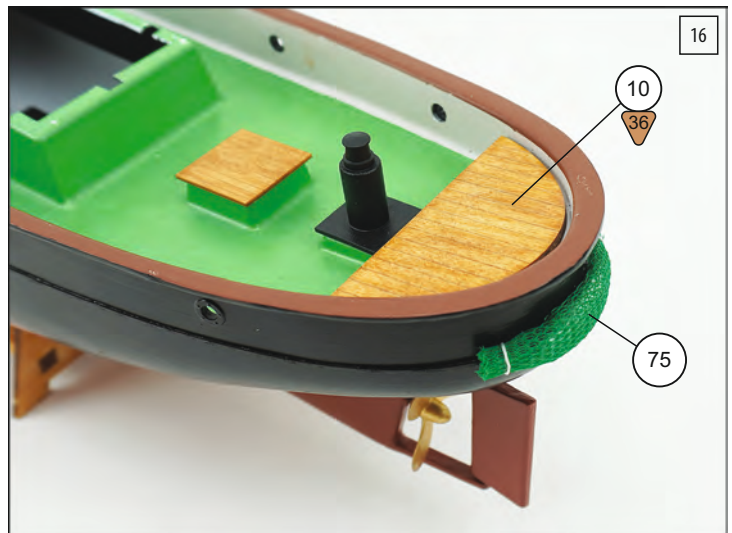
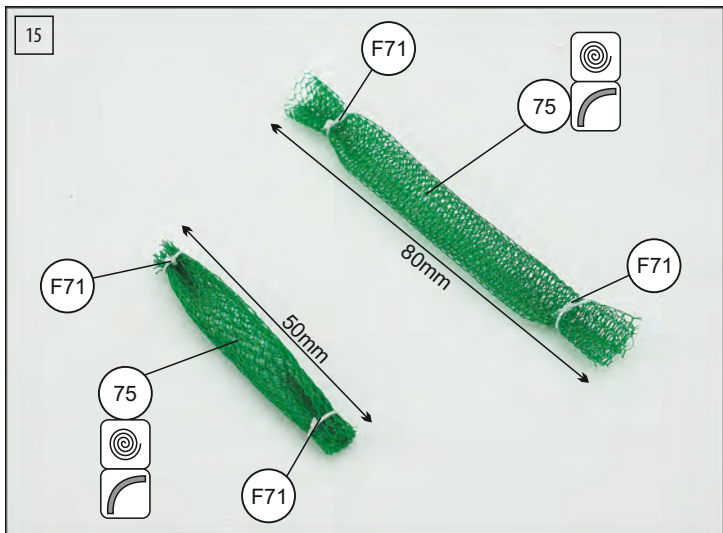
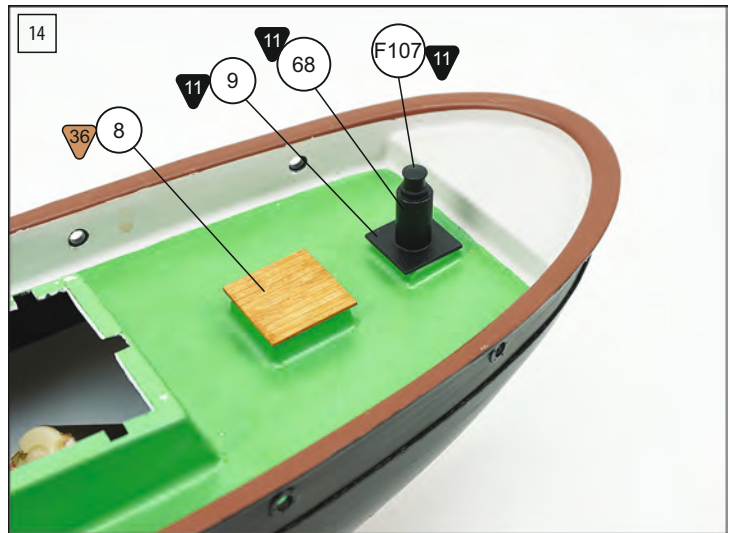
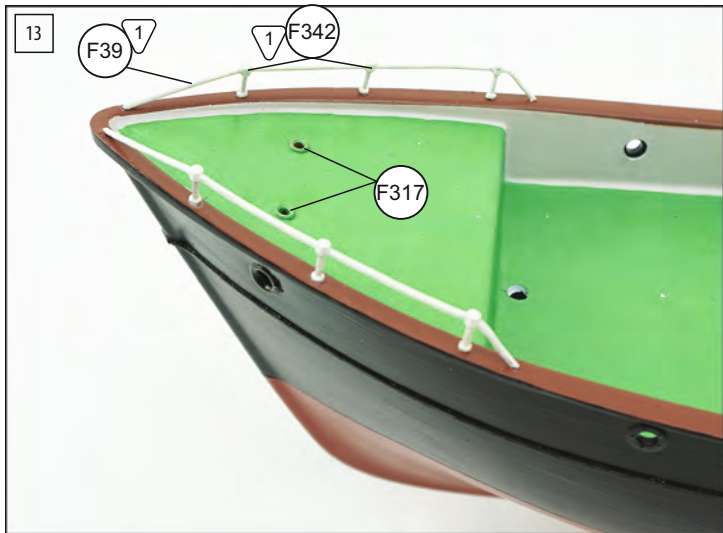
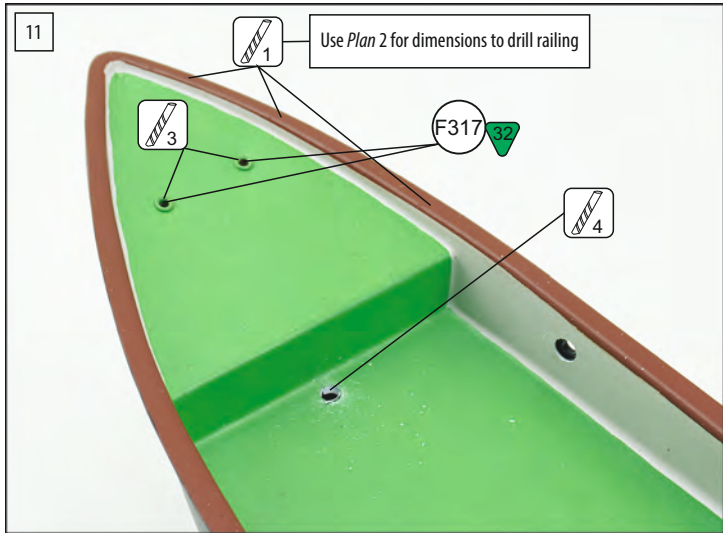
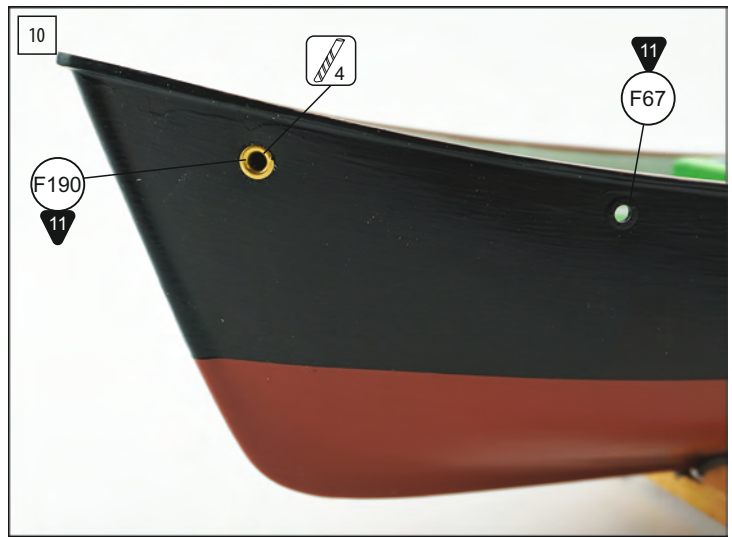
To see our color conversion chart please visit <https://www.billingboats.com/faq>

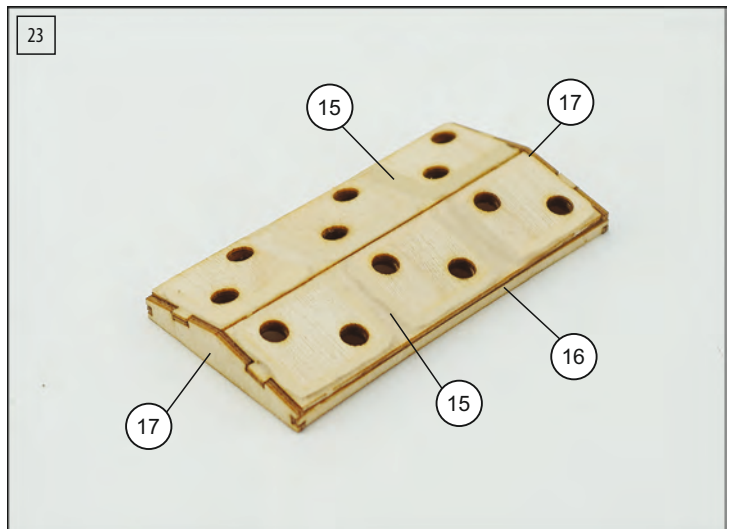
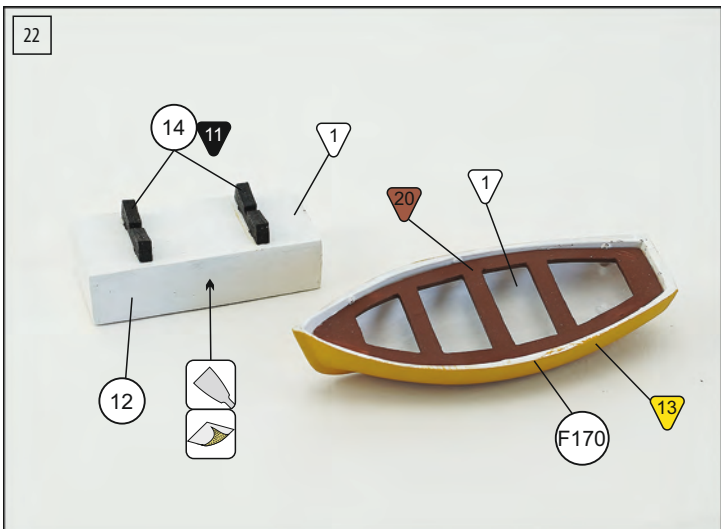
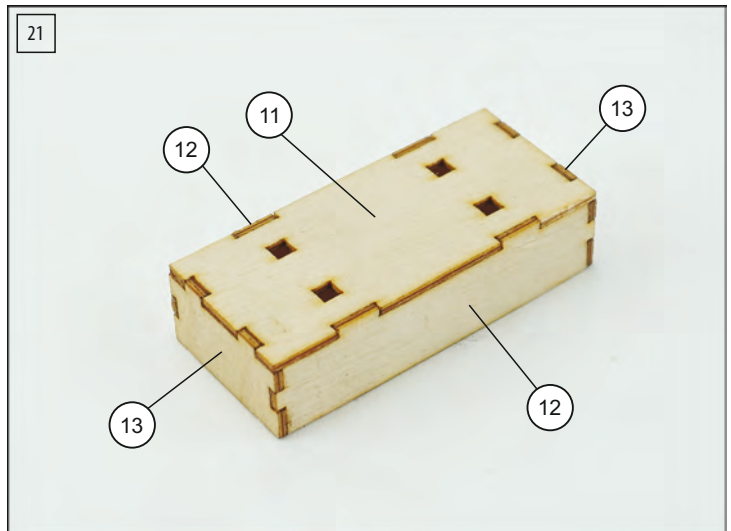
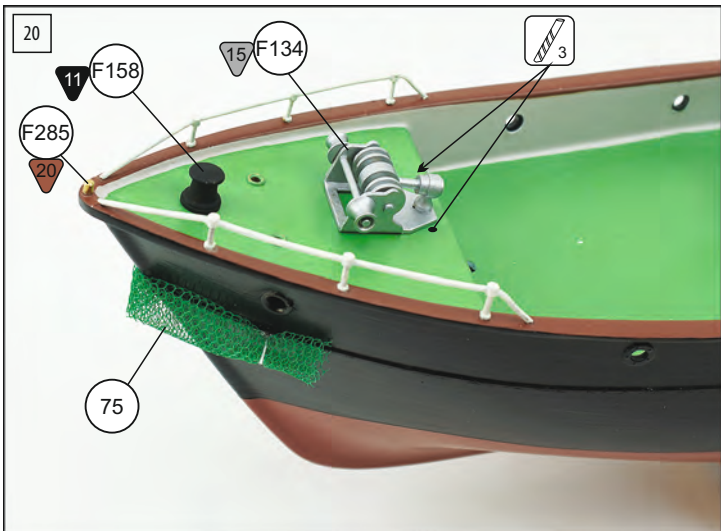
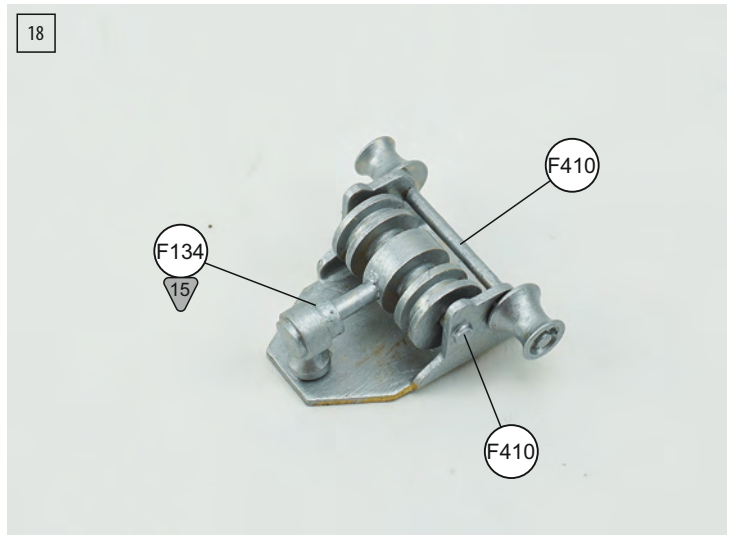
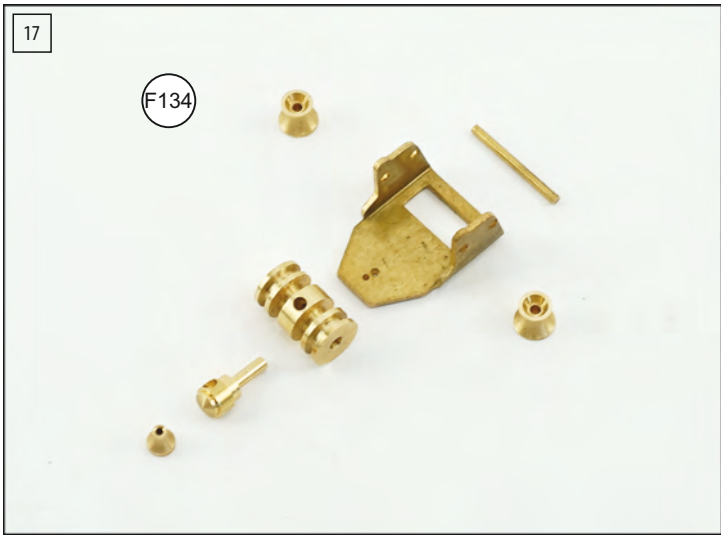
Til denne model er mahogni bejdse og farver med følgende numre nødvendige:
 For this model is mahogany stain and colours with the following numbers should be used:
 Für dieses Modell sind Mahagoni Beize und Farben mit den folgenden Nummern notwendig:
 Pour ce modèle, le mordant et les couleurs avec les numéros suivants doivent être employées:
 Voor dit model zijn kleuren met de volgende nummers nodig:
 Para est modelo se necesitan mordiente et colores con los siguientes números:
 Per questo modello occorrono inchiostro tinteggiatore "mogano" e colori con questi numeri:
 Pinte o modelo com tintura cor Mogno e as cores sugeridas da Billing Boats:
 W przypadku tego modelu należy użyć bejcy mahoniowej oraz farby o numerach:

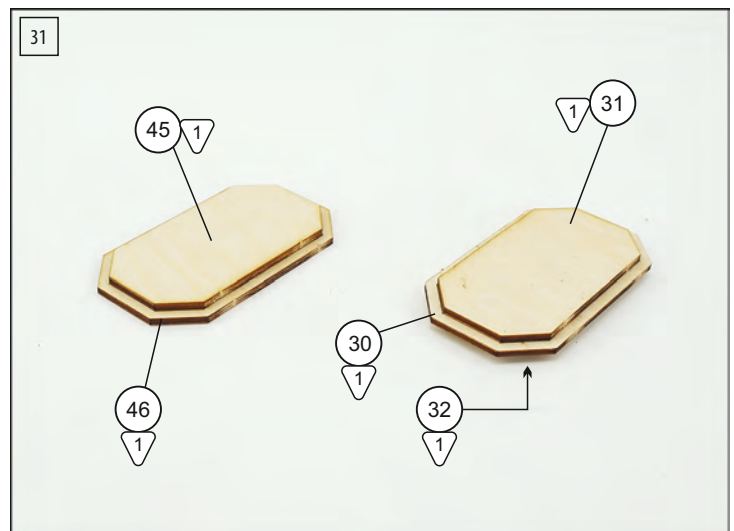
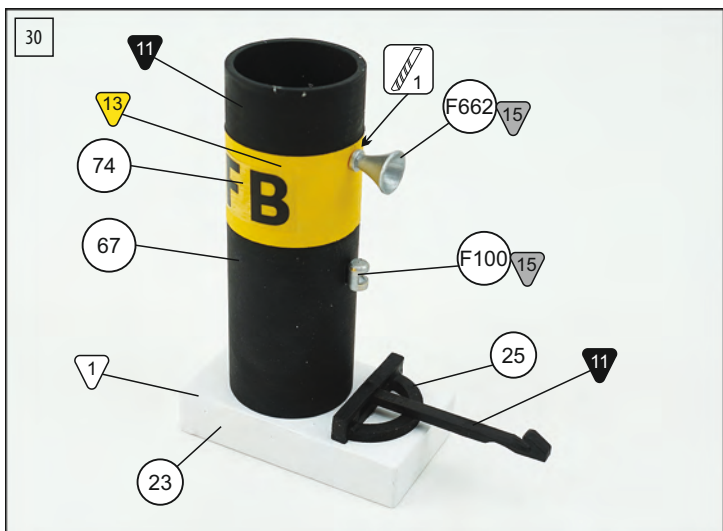
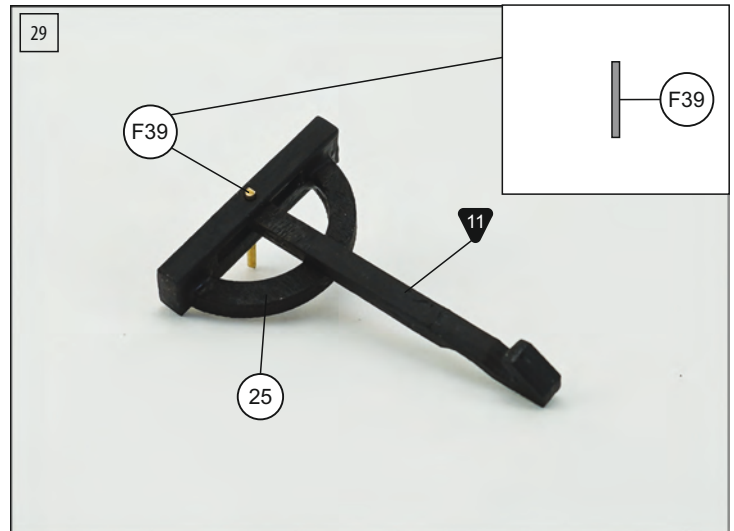
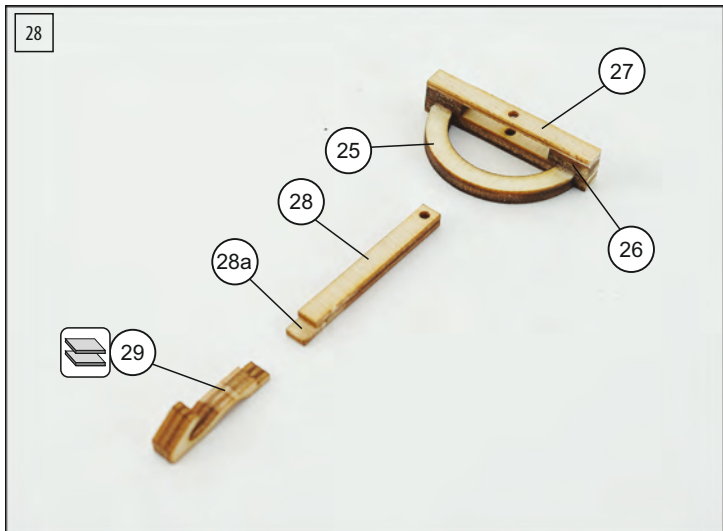
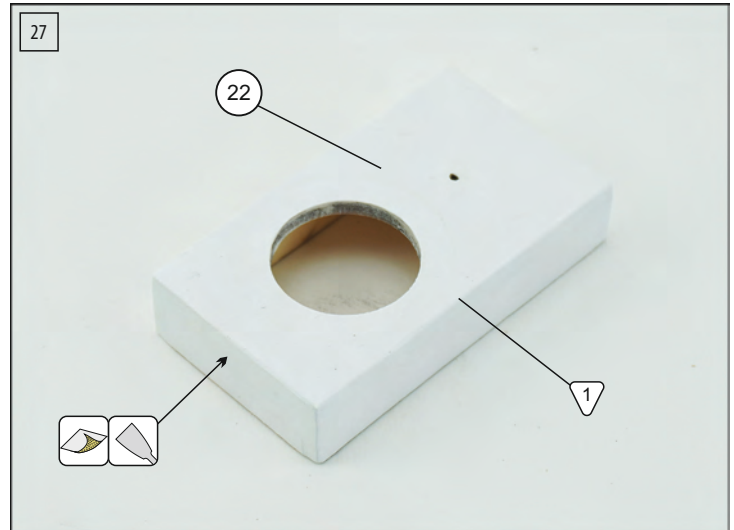
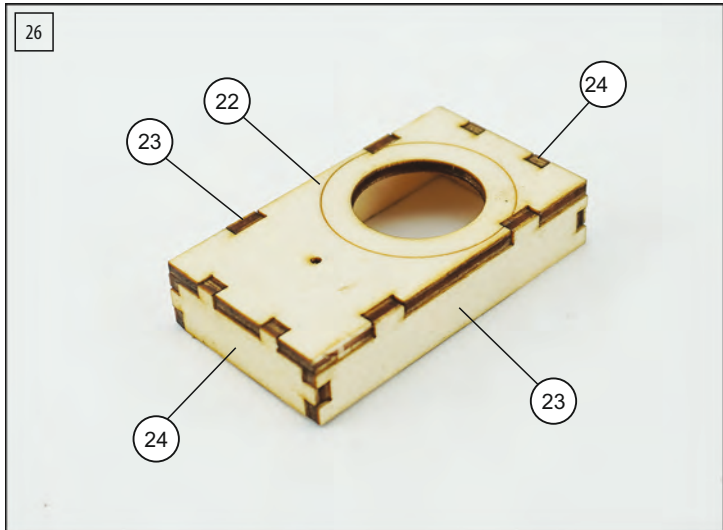
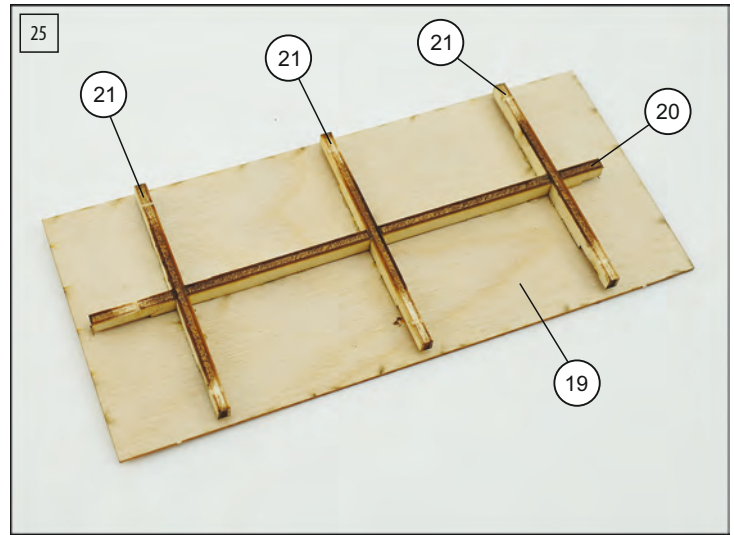
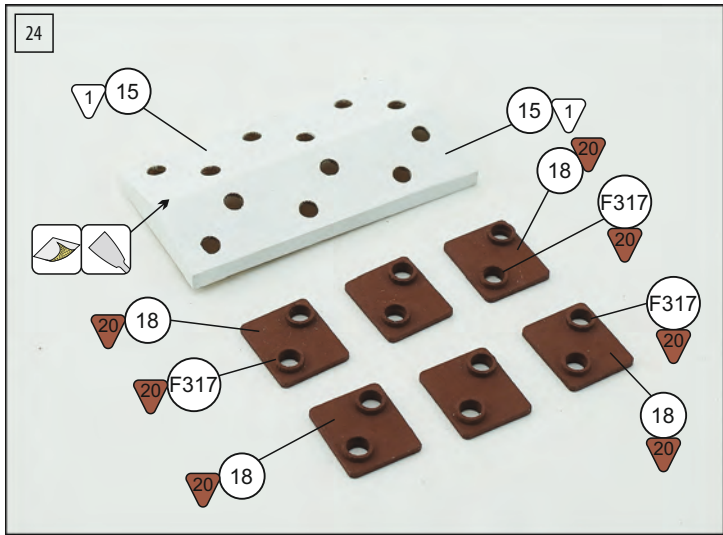
Billing 1 = White
 Billing 6 = Hull Red
 Billing 11 = Black
 Billing 13 = Trainer Yellow
 Billing 15 = Silver
 Billing 16 = Gold
 Billing 20 = Satin Brown
 Billing 32 = Lime
 Billing 35 = Signal Red
 Billing 36 = Mahogany Stain

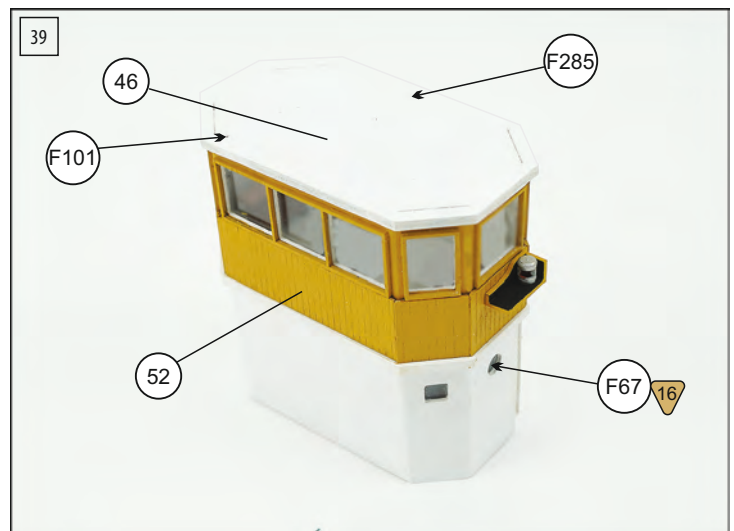
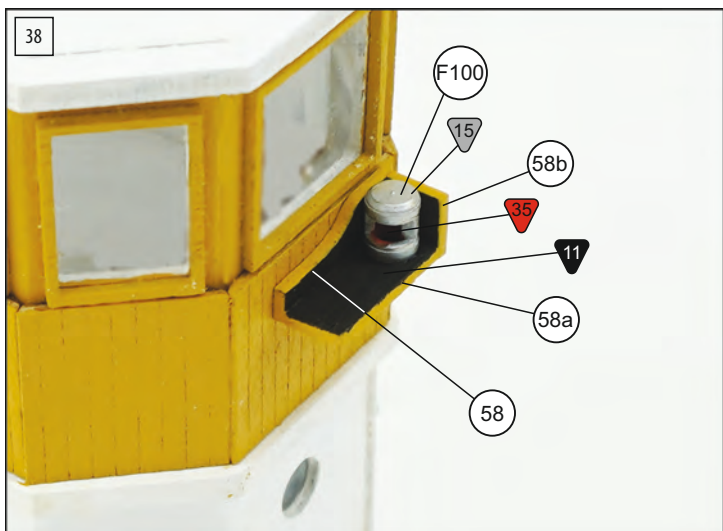
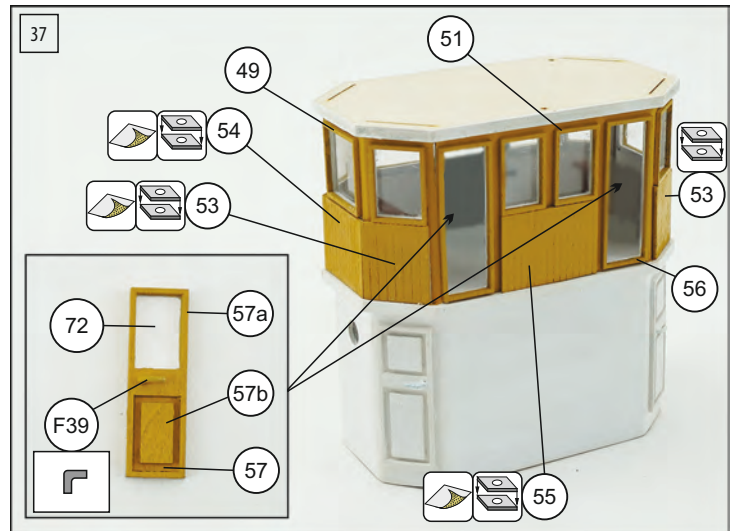
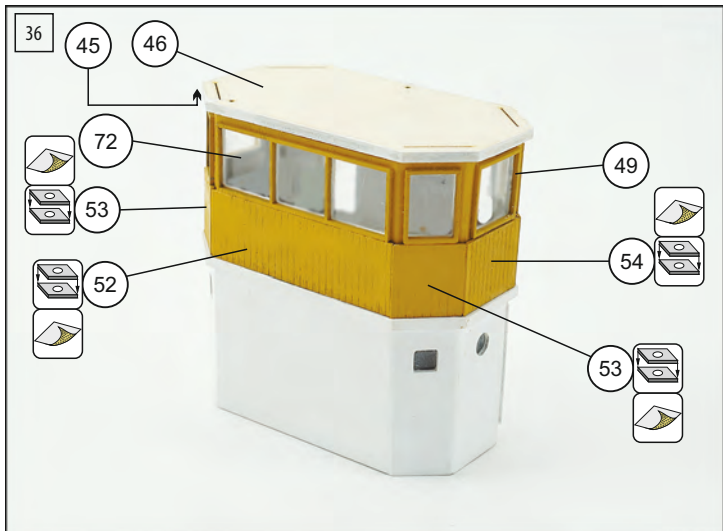
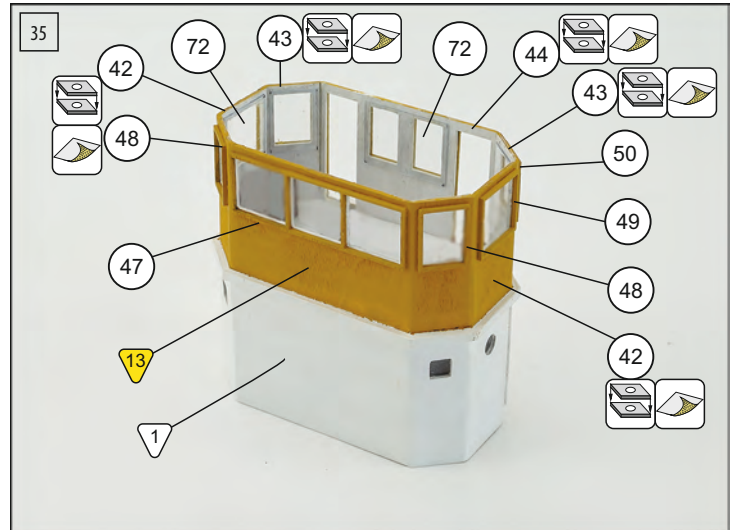
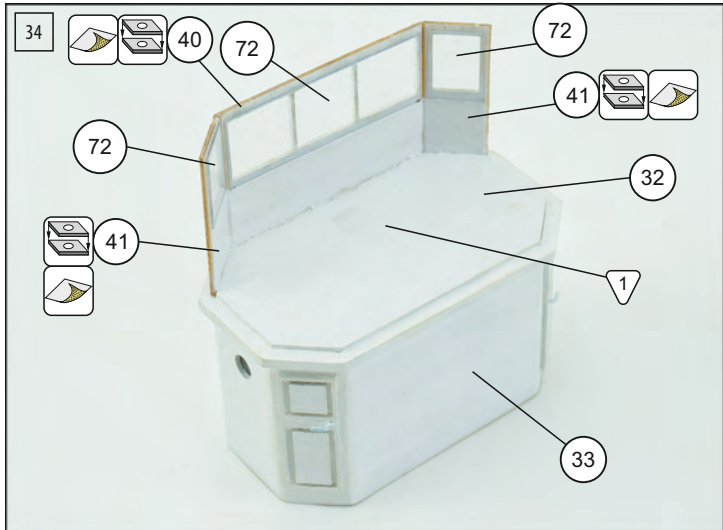
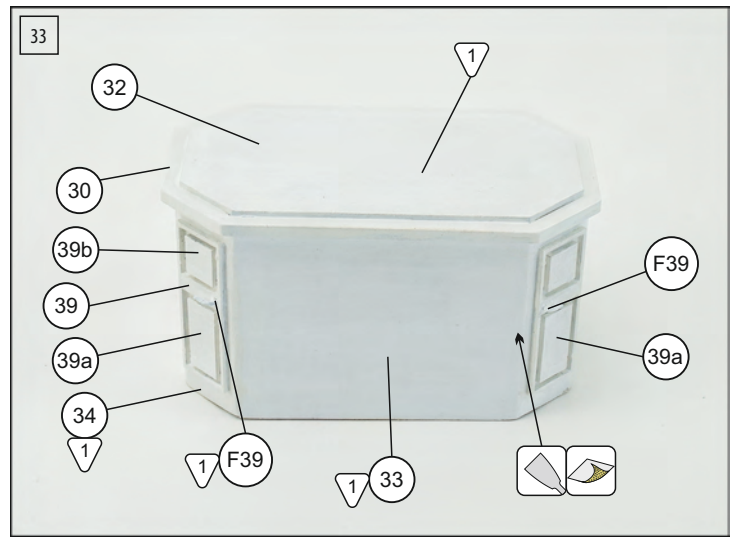
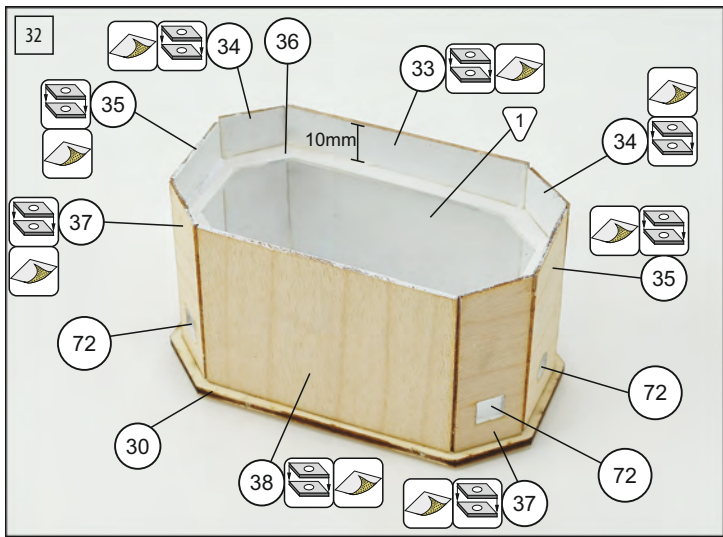
	Part number		Cut out		Paint with primer paint
	Paint number (* alternative colour)		Use putty (fill and sand)		Use cyanoacrylate glue
	Wood stain		Fit to other parts		Give shape (before sticking)
	Rope number		Part made with layers		Give shape (before sticking, if necessary use water)
	Give shape (for example use sand paper)		Drill a hole (x mm)		Roll up

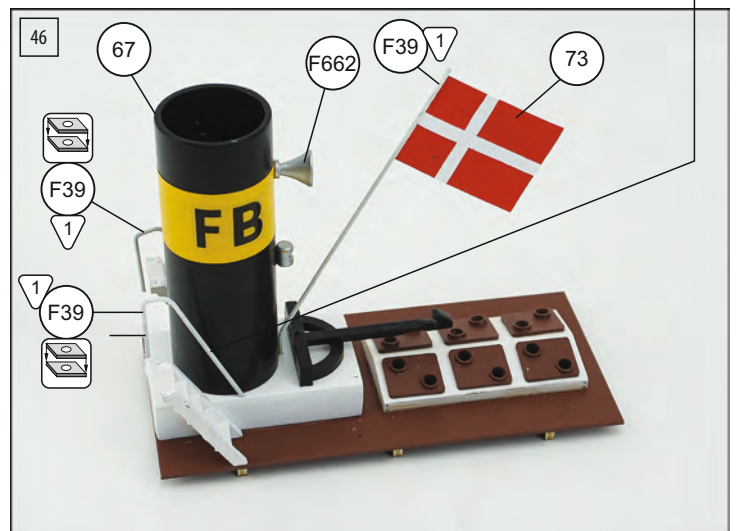
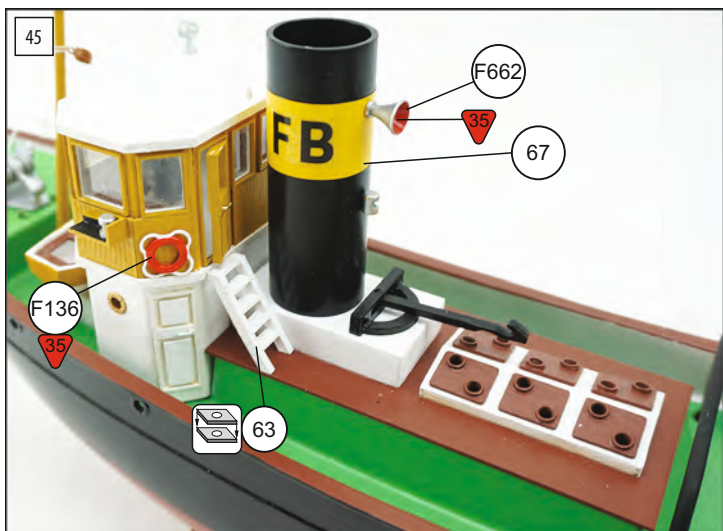
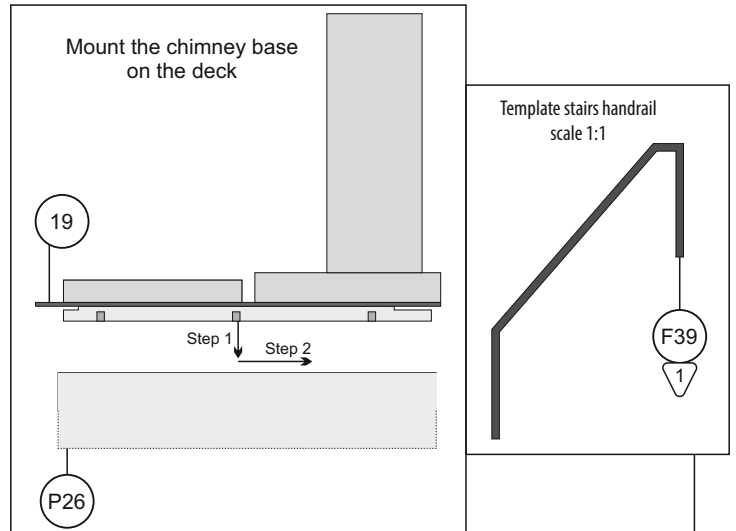
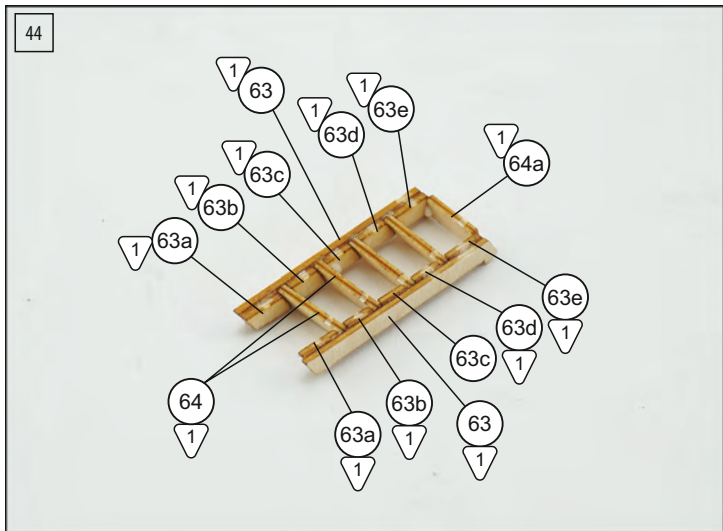
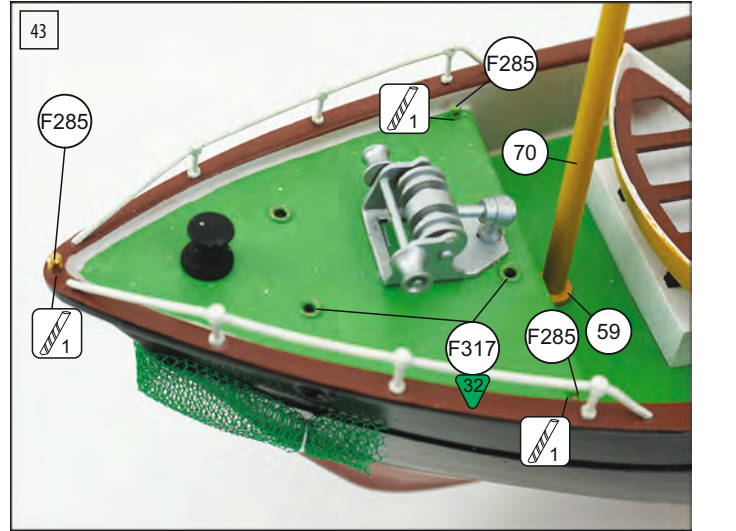
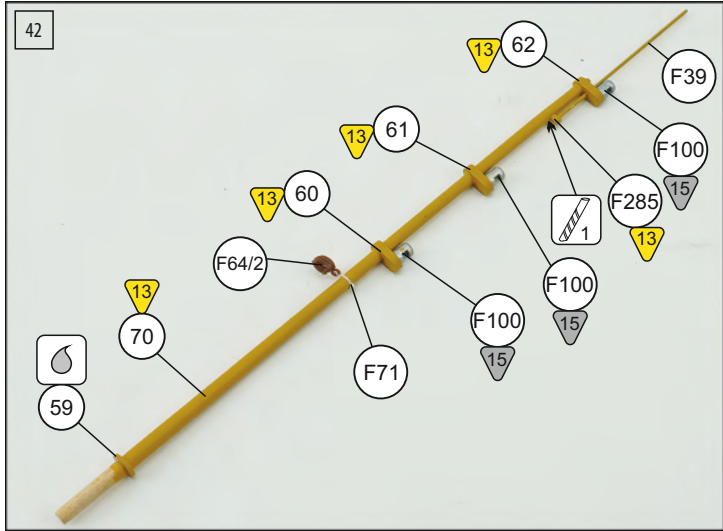
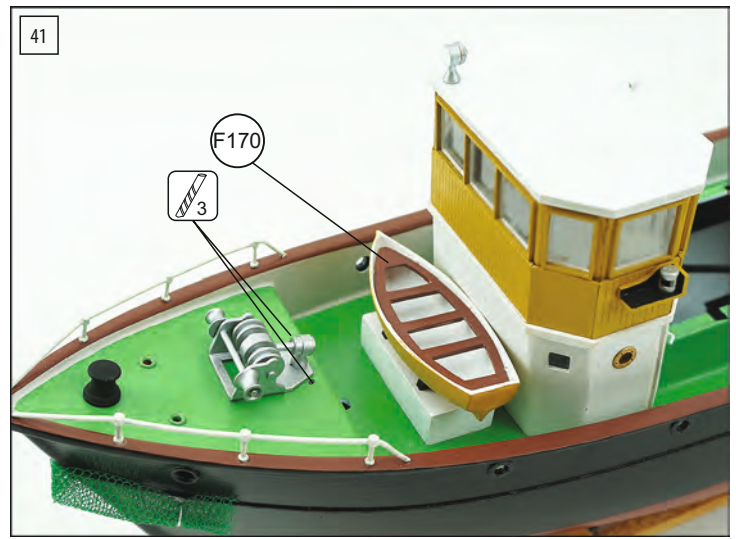
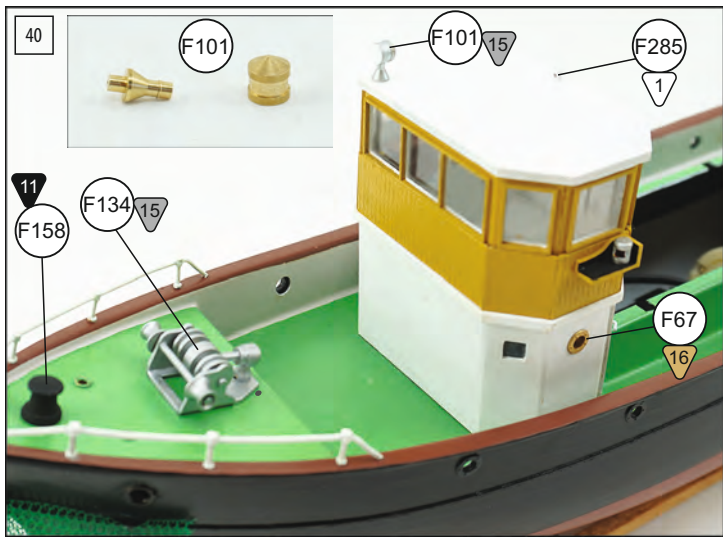


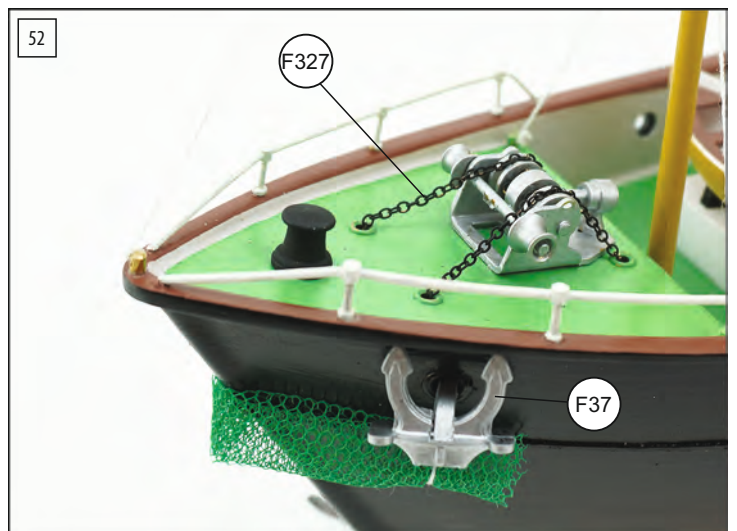
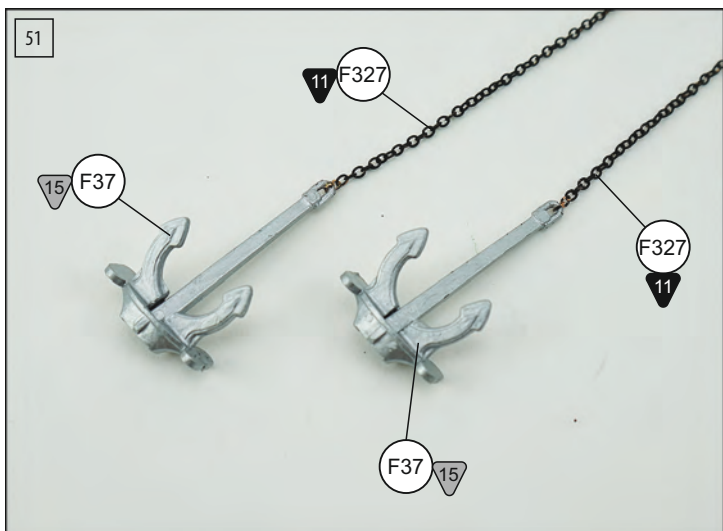
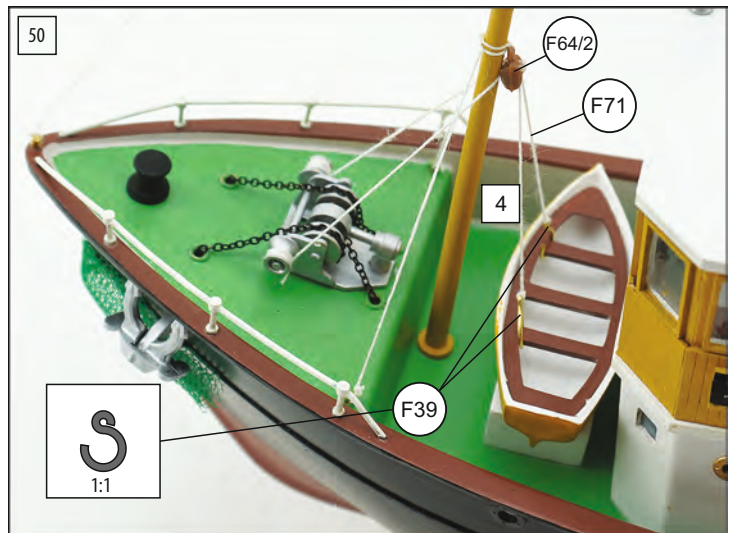
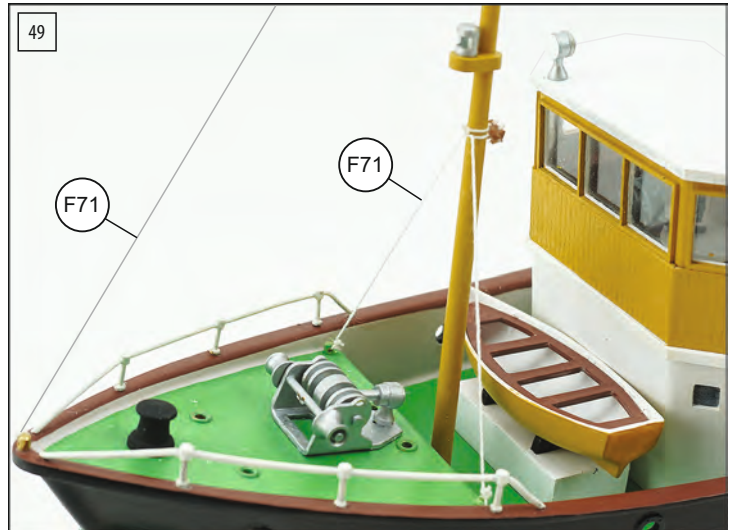
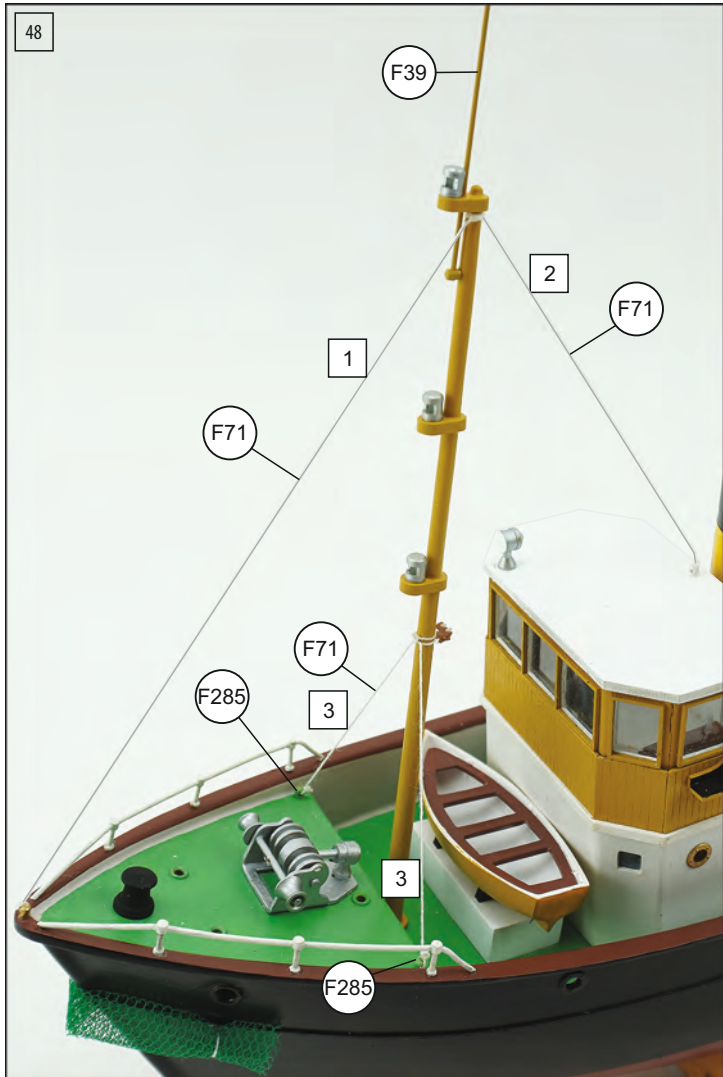
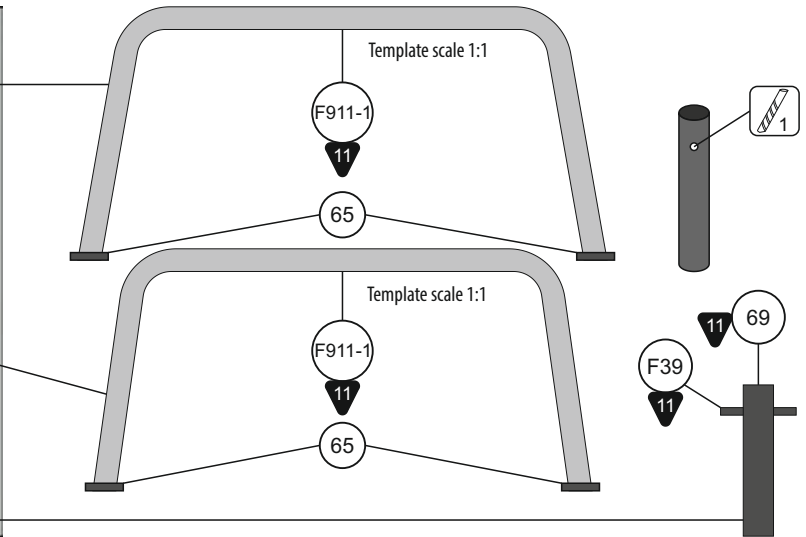
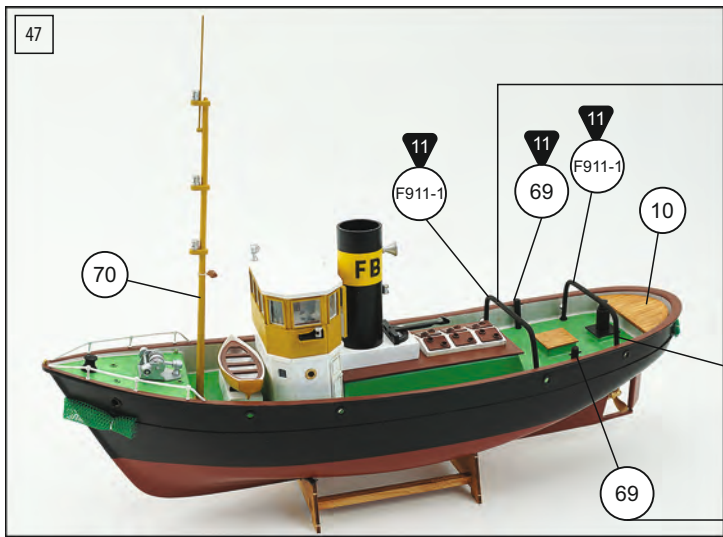






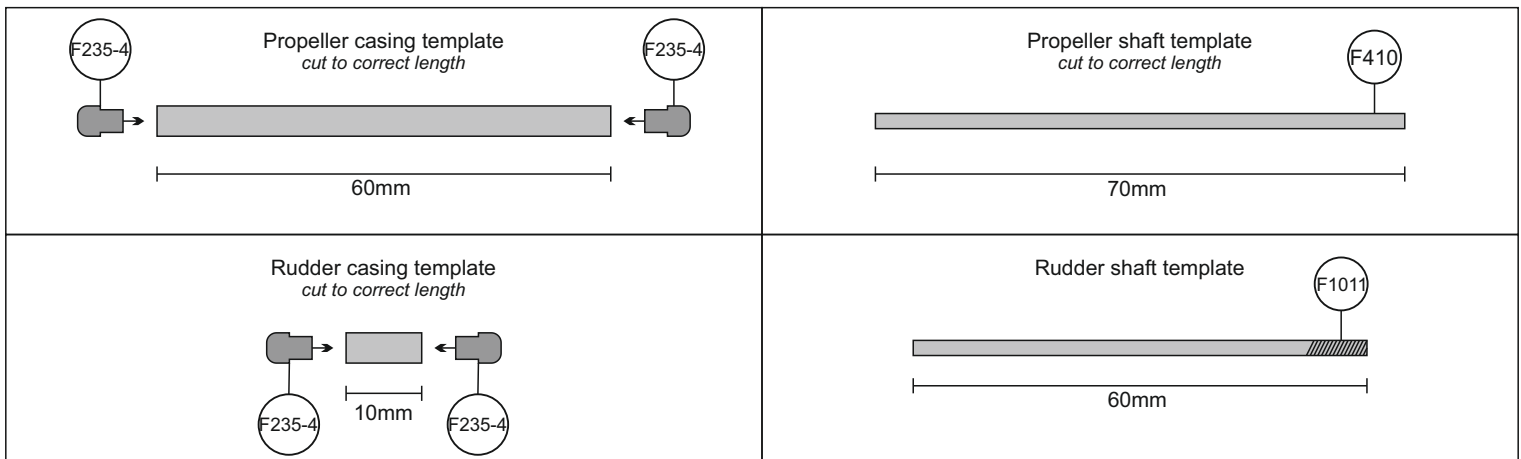
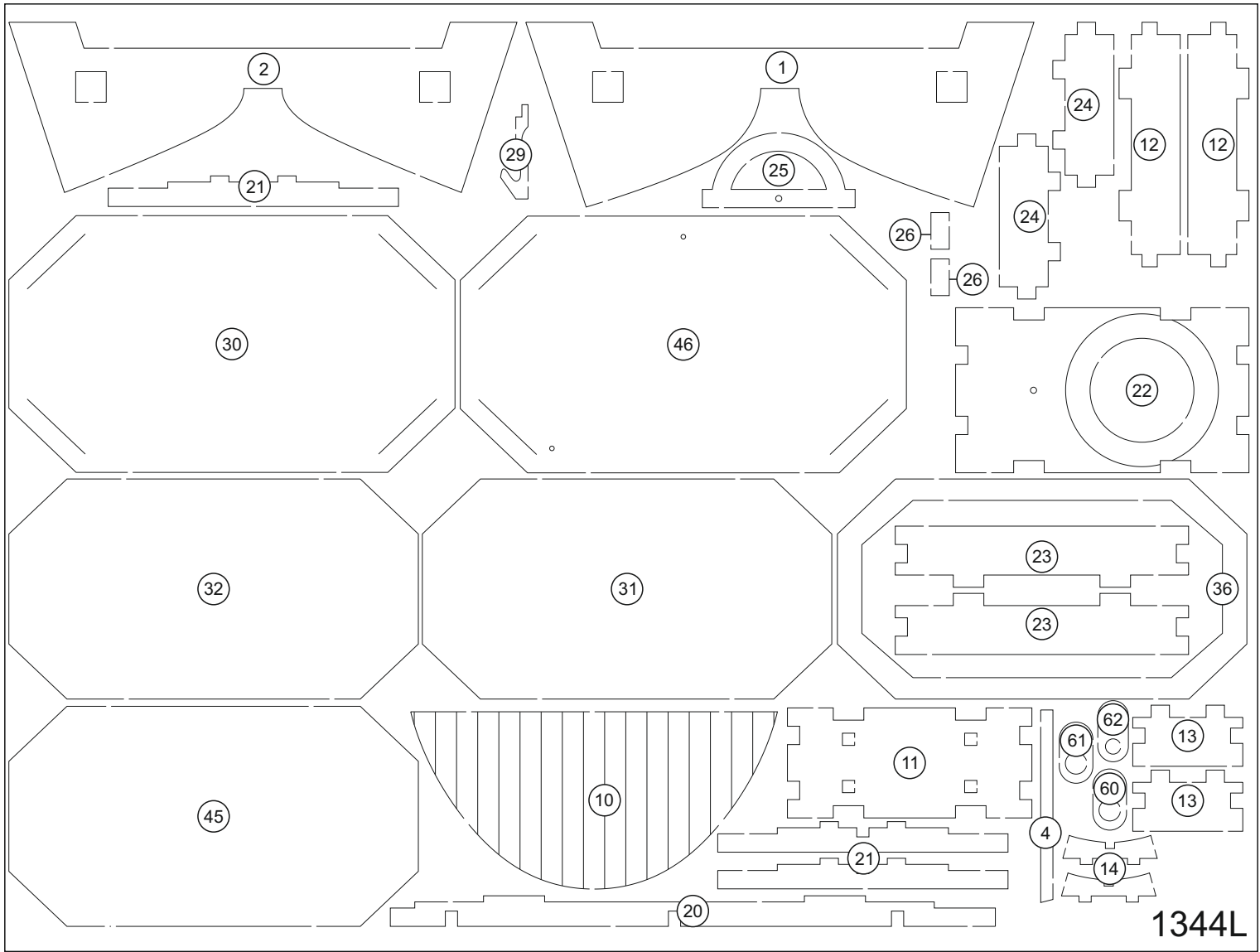












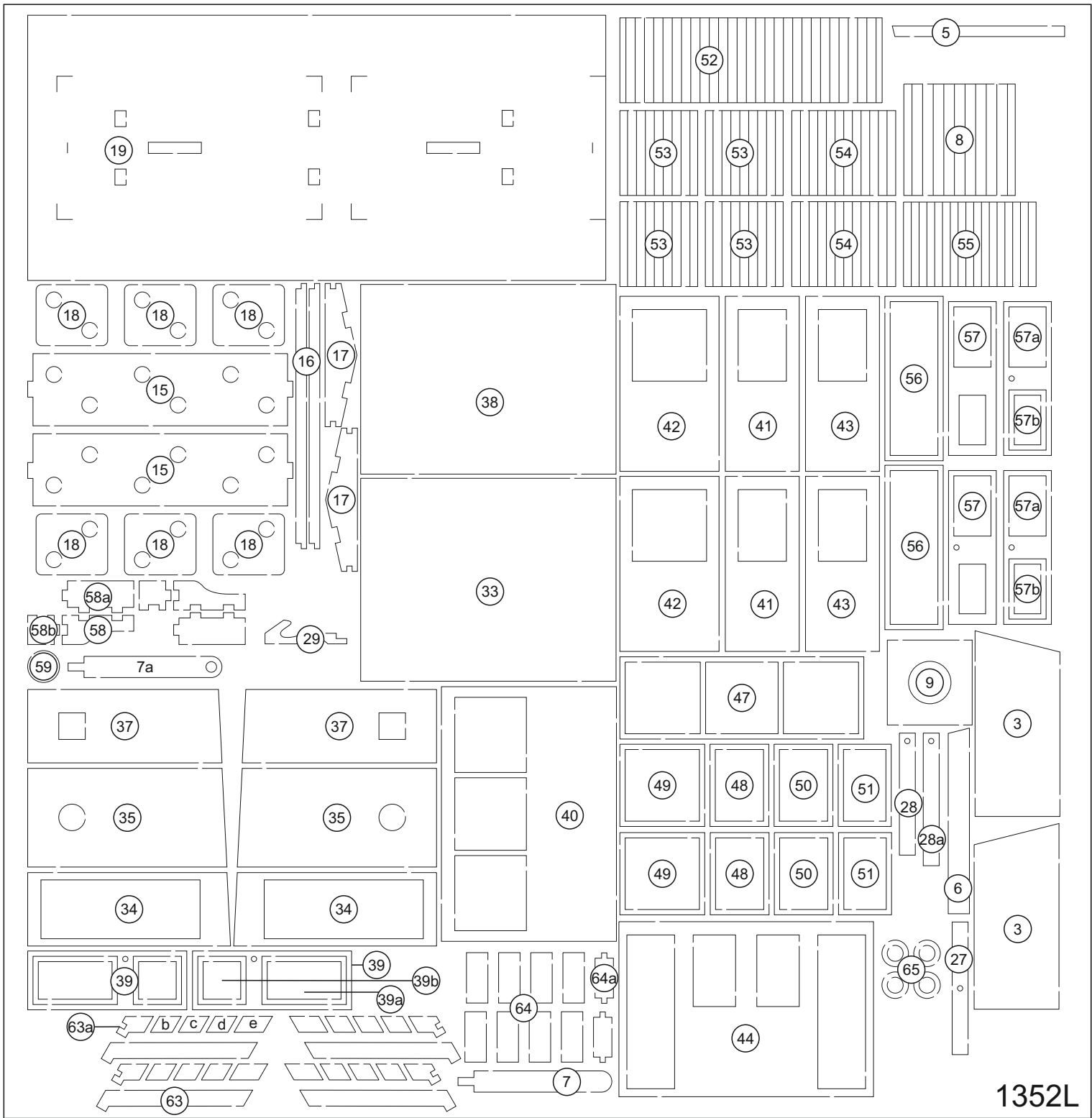


Table of contents for YMER Art. No. 244

Pcs.	No.	Dimension	Material	Found in	DK	GB	D	F	NL
1	1	2 mm x-veneér	1344L		Sokkel	Base	Sokkel	Socle	Sokkel
1	2	2 mm x-veneér	1344L		Sokkel	Base	Sokkel	Socle	Sokkel
2	3	1 mm x-veneér	1352L		Ror	Rudder	Ruder	Gouvernail	Roer
1	4	2 mm x-veneér	1344L		Ror	Rudder	Ruder	Gouvernail	Roer
1	5	1 mm x-veneér	1352L		Ror	Rudder	Ruder	Gouvernail	Roer
1	6	1 mm x-veneér	1352L		Ror	Rudder	Ruder	Gouvernail	Roer
2	7 – 7a	1 mm x-veneér	1352L		Ror	Rudder	Ruder	Gouvernail	Roer
1	8	1 mm x-veneér	1352L		Sokkel	Base	Sokkel	Socle	Sokkel
1	9	1 mm x-veneér	1352L		Sokkel	Base	Sokkel	Socle	Sokkel
1	10	2 mm x-veneér	1344L		Dæk	Deck	Deck	Pont	Dek
1	11	2 mm x-veneér	1344L		Sokkel	Base	Sokkel	Socle	Sokkel
2	12	2 mm x-veneér	1344L		Sokkel	Base	Sokkel	Socle	Sokkel
2	13	2 mm x-veneér	1344L		Sokkel	Base	Sokkel	Socle	Sokkel
2	14	2 mm x-veneér	1344L		Sokkel	Base	Sokkel	Socle	Sokkel
2	15	1 mm x-veneér	1352L		Skylight	Skylight	Oberlicht	Claire-voie	Bovenlicht
2	16	1 mm x-veneér	1352L		Skylight	Skylight	Oberlicht	Claire-voie	Bovenlicht
2	17	1 mm x-veneér	1352L		Skylight	Skylight	Oberlicht	Claire-voie	Bovenlicht
6	18	1 mm x-veneér	1352L		Skylight	Skylight	Oberlicht	Claire-voie	Bovenlicht
1	19	1 mm x-veneér	1352L		Sokkel	Base	Sokkel	Socle	Sokkel
1	20	2 mm x-veneér	1344L		Sokkel	Base	Sokkel	Socle	Sokkel
3	21	2 mm x-veneér	1344L		Sokkel	Base	Sokkel	Socle	Sokkel
1	22	2 mm x-veneér	1344L		Skorsten	Chimney	Schornstein	Cheminée	Schoorsteen
2	23	2 mm x-veneér	1344L		Skorsten	Chimney	Schornstein	Cheminée	Schoorsteen
2	24	2 mm x-veneér	1344L		Skorsten	Chimney	Schornstein	Cheminée	Schoorsteen
1	25	2 mm x-veneér	1344L		Krog	Hook	Haken	Accrocher	Haak
2	26	2 mm x-veneér	1344L		Krog	Hook	Haken	Accrocher	Haak
1	27	1 mm x-veneér	1352L		Krog	Hook	Haken	Accrocher	Haak
2	28-28a	1 mm x-veneér	1352L		Krog	Hook	Haken	Accrocher	Haak
1	29	1 mm x-veneér	1352L		Krog	Hook	Haken	Accrocher	Haak
1	29	2 mm x-veneér	1344L		Krog	Hook	Haken	Accrocher	Haak
1	30	2 mm x-veneér	1344L		Sokkel	Base	Sokkel	Socle	Sokkel
1	31	2 mm x-veneér	1344L		Sokkel	Base	Sokkel	Socle	Sokkel
1	32	2 mm x-veneér	1344L		Sokkel	Base	Sokkel	Socle	Sokkel
1	33	1 mm x-veneér	1352L		Væg	Wall	Wand	Mur	Muur
2	34	1 mm x-veneér	1352L		Væg	Wall	Wand	Mur	Muur
2	35	1 mm x-veneér	1352L		Væg	Wall	Wand	Mur	Muur
1	36	2 mm x-veneér	1344L		Støtte	Support	Stütze	Support	Steun
2	37	1 mm x-veneér	1352L		Væg	Wall	Wand	Mur	Muur
1	38	1 mm x-veneér	1352L		Væg	Wall	Wand	Mur	Muur

Table of contents for YMER Art. No. 244

Pcs.	No.	Dimension	Material	Found in	DK	GB	D	F	NL
6	39 -39b	1 mm x-veneér	1352L		Dør	Door	Tür	Porte	Deur
1	40	1 mm x-veneér	1352L		Væg	Wall	Wand	Mur	Muur
2	41	1 mm x-veneér	1352L		Væg	Wall	Wand	Mur	Muur
2	42	1 mm x-veneér	1352L		Væg	Wall	Wand	Mur	Muur
2	43	1 mm x-veneér	1352L		Væg	Wall	Wand	Mur	Muur
1	44	1 mm x-veneér	1352L		Væg	Wall	Wand	Mur	Muur
1	45	2 mm x-veneér	1344L		Tag	Roof	Dach	Toit	Dak
1	46	2 mm x-veneér	1344L		Tag	Roof	Dach	Toit	Dak
1	47	1 mm x-veneér	1352L		Vindue	Window	Fenster	Fenêtre	Raam
2	48	1 mm x-veneér	1352L		Vindue	Window	Fenster	Fenêtre	Raam
2	49	1 mm x-veneér	1352L		Vindue	Window	Fenster	Fenêtre	Raam
2	50	1 mm x-veneér	1352L		Vindue	Window	Fenster	Fenêtre	Raam
2	51	1 mm x-veneér	1352L		Vindue	Window	Fenster	Fenêtre	Raam
1	52	1 mm x-veneér	1352L		Beklædning	Sheathing	Ummanteln	Revêtement	Moord
4	53	1 mm x-veneér	1352L		Beklædning	Sheathing	Ummanteln	Revêtement	Moord
2	54	1 mm x-veneér	1352L		Beklædning	Sheathing	Ummanteln	Revêtement	Moord
1	55	1 mm x-veneér	1352L		Beklædning	Sheathing	Ummanteln	Revêtement	Moord
2	56	1 mm x-veneér	1352L		Dør	Door	Tür	Porte	Deur
1	57-57b	1 mm x-veneér	1352L		Dør	Door	Tür	Porte	Deur
6	58-58b	1 mm x-veneér	1352L		Lampe	Lamp	Lampen	Lampe	Lamp
1	59	1 mm x-veneér	1352L		Mast	Mast	Mast	Mât	Mast
1	60	2 mm x-veneér	1344L		Mast	Mast	Mast	Mât	Mast
1	61	2 mm x-veneér	1344L		Mast	Mast	Mast	Mât	Mast
1	62	2 mm x-veneér	1344L		Mast	Mast	Mast	Mât	Mast
4	63	1 mm x-veneér	1352L		Trappe	Stairs	Treppe	Escalier	Trap
20	63a-63e	1 mm x-veneér	1352L		Trappe	Stairs	Treppe	Escalier	Trap
8	64	1 mm x-veneér	1352L		Trappe	Stairs	Treppe	Escalier	Trap
2	64a	1 mm x-veneér	1352L		Trappe	Stairs	Treppe	Escalier	Trap
4	65	1 mm x-veneér	1352L		Støtte	Support	Stütze	Support	Steun
1	66	5x5x300mm	Wood	TS	Sokkel	Base	Socket	Socle	Sokkel
1	67	ø25x68mm	PVC	TS	Skorsten	Chimney	Schornstein	Cheminée	Schoorsteen
1	68	ø8x20mm	Wood	TS	Rundstok	Stick	Rundstock	Baguette ronde	Rondhout
1	69	ø6x110mm	Wood	TS	Rundstok	Stick	Rundstock	Baguette ronde	Rondhout
1	70	ø4x180mm	Wood	TS	Mast	Mast	Mast	Mât	Mast
4	71	0,7x1x275mm	Wood	TS	Lister	Strip	Leisten	Baguettes	Strips
1	72	50x30mm	Foil	VEJ	Vindue	Window	Fenster	Fenêtre	Raam
1	73		Flag	VEJ	Flag	Flag	Flagge	Drapeau	Vlag
1	74		Sticker	VEJ	Transfer	Transfer	Abziehbild	Decalomanies	Transfer
1	75	100x260mm	Net	VEJ	Net	Net	Netz	Filet	Net

Table of contents for YMER Art. No. 244

Pcs.	No.	Dimension	Material	Found in	DK	GB	D	F	NL
1	76	ø2x60mm	Brass	TS	Propelaksel	Propeller shaft	Stevenrohr	Arbre porte hélice	Schroefas
1	P25		Plastic		Skrog	Hull	Rumpf	Coque	Romp
1	P26		Plastic		Dæk	Deck	Deck	Pont	Dek
1		A4		VEJ	Byggevejledning	Building instruction	Bauanleitung	Instruction de montage	Bouwbeschrijving
1		A3		VEJ	Tegning	Drawing	Zeichnung	Plan	Tekening
2	F37	15mm	Plastic	FS	Anker	Anchor	Anker	Ancre	Anker
2	F39	ø1x250mm	Brass	TS	Messingtråd	Wire	Messingdraht	Fil de laiton	Messingdraad
1	F45	24,5mm	Plastic	FS	Skibsskrue	Propeller	Schiffsschraube	Hélice	Propeller
1	F64/2	5mm	Plastic	FS	Blokke	Block	Blöcke	Poulie	Blokken
10	F67	ø5mm	Plastic	FS	Kooje	Portlight	Bullauge	Hublot	Patrijspoort
1	F71	1m	Rope	TS	Ræb	Rope	Seil	Cordage	Touw
1	F73	1m	Rope	TS	Ræb	Rope	Seil	Cordage	Touw
6	F100	ø4x5mm	Brass	FS	Lys	Light	Licht	Feux	Licht
1	F101	5mm	Brass	FS	Spotlight	Searchlight	Scheinwerf	Projecteur	Schijnwerper
1	F107	ø6x6mm	Brass	FS	Kapstan	Capstan	Kapstan	Cabestan	Kaapstander
1	F134		Brass	FS	Spil	Winch	Winde	Treuil	Winch
2	F136	ø12mm	Plastic	FS	Redningskrans	Lifering	Retningsring	Ceinture sauvetage	Reddingsboei
1	F158	ø8x8mm	Brass	FS	Kapstan	Capstan	Kapstan	Cabestan	Kaapstander
1	F170	64mm	Plastic	FS	Redningsbåd	Lifeboat	Retningsboot	Canot de sauvetage	Reddingsboot
2	F190	ø3,8mm	Brass	FS	Hawse-rør	Hawse pipe	Hawse Pipe	Pipe hawse	Hawse -pijp
4	F235-4	ø4x6mm	Brass	FS	Bøsning	Bushing	Buchsen	Baque	Busje
5	F285	6mm	Brass	FS	Øjebolt	Eye bolt	Augbolzen	Pitons	Oogbout
16	F317	ø4x2mm	Plastic	FS	Kooje	Portlight	Bullauge	Hublot	Patrijspoort
1	F327	ø1,5x300mm	Metal	FS	Kæde	Chain	Kette	Chaîne	Ketting
11	F342	10mm	Brass	FS	Gelænder	Rail	Geländer	Bastingage	Railing
1	F410	ø2x100mm	Brass	TS			Stevenrohr		Schroefas
1	F662	ø8x10,5mm	Brass	FS	Sirene	Siren	Sirene	Sirène	Sirene
2	F911-1	ø3x250mm	Aluminium	FS	Tråd	Wire	Draht	Fil	Draad
1	F1011	ø2x60mm	Brass	TS	Ror skaft	Rudder shaft	Ruderwelle	Arbre du gouvernail	Roeras

Table of contents for YMER Art. No. 244

Pcs.	No.	Dimension	Material	Found in	E	I	P	PL
1	1	2 mm x-veneér	1344L		Base	Base	Base	Podstawa
1	2	2 mm x-veneér	1344L		Base	Base	Base	Podstawa
2	3	1 mm x-veneér	1352L		Timón	Timone	Leme	Ster
1	4	2 mm x-veneér	1344L		Timón	Timone	Leme	Ster
1	5	1 mm x-veneér	1352L		Timón	Timone	Leme	Ster
1	6	1 mm x-veneér	1352L		Timón	Timone	Leme	Ster
2	7 - 7a	1 mm x-veneér	1352L		Timón	Timone	Leme	Ster

Table of contents for YMER Art. No. 244

Pcs.	No.	Dimension	Material	Found in	E	I	P	PL
1	8	1 mm x-veneér	1352L		Base	Base	Base	Podstawa
1	9	1 mm x-veneér	1352L		Base	Base	Base	Podstawa
1	10	2 mm x-veneér	1344L		Cubierta	Ponte	Convés	Pokład
1	11	2 mm x-veneér	1344L		Base	Base	Base	Podstawa
2	12	2 mm x-veneér	1344L		Base	Base	Base	Podstawa
2	13	2 mm x-veneér	1344L		Base	Base	Base	Podstawa
2	14	2 mm x-veneér	1344L		Base	Base	Base	Podstawa
2	15	1 mm x-veneér	1352L		Claraboya	Osteriggio	Clarabóia	Światlik
2	16	1 mm x-veneér	1352L		Claraboya	Osteriggio	Clarabóia	Światlik
2	17	1 mm x-veneér	1352L		Claraboya	Osteriggio	Clarabóia	Światlik
6	18	1 mm x-veneér	1352L		Claraboya	Osteriggio	Clarabóia	Światlik
1	19	1 mm x-veneér	1352L		Base	Base	Base	Podstawa
1	20	2 mm x-veneér	1344L		Base	Base	Base	Podstawa
3	21	2 mm x-veneér	1344L		Base	Base	Base	Podstawa
1	22	2 mm x-veneér	1344L		Chimenea	Ciminiera	Chaminé	Komin
2	23	2 mm x-veneér	1344L		Chimenea	Ciminiera	Chaminé	Komin
2	24	2 mm x-veneér	1344L		Chimenea	Ciminiera	Chaminé	Komin
1	25	2 mm x-veneér	1344L		Gancho	Gancio	Gancho	Hak
2	26	2 mm x-veneér	1344L		Gancho	Gancio	Gancho	Hak
1	27	1 mm x-veneér	1352L		Gancho	Gancio	Gancho	Hak
2	28-28a	1 mm x-veneér	1352L		Gancho	Gancio	Gancho	Hak
1	29	1 mm x-veneér	1352L		Gancho	Gancio	Gancho	Hak
1	29	2 mm x-veneér	1344L		Gancho	Gancio	Gancho	Hak
1	30	2 mm x-veneér	1344L		Base	Base	Base	Podstawa
1	31	2 mm x-veneér	1344L		Base	Base	Base	Podstawa
1	32	2 mm x-veneér	1344L		Base	Base	Base	Podstawa
1	33	1 mm x-veneér	1352L		Muro	Parete	Parede	Ściana
2	34	1 mm x-veneér	1352L		Muro	Parete	Parede	Ściana
2	35	1 mm x-veneér	1352L		Muro	Parete	Parede	Ściana
1	36	2 mm x-veneér	1344L		Soporte	Supporto	Supporte	Wspornik
2	37	1 mm x-veneér	1352L		Muro	Parete	Parede	Ściana
1	38	1 mm x-veneér	1352L		Muro	Parete	Parede	Ściana
6	39 -39b	1 mm x-veneér	1352L		Puerta	Porta	Porta	Drzwi
1	40	1 mm x-veneér	1352L		Muro	Parete	Parede	Ściana
2	41	1 mm x-veneér	1352L		Muro	Parete	Parede	Ściana
2	42	1 mm x-veneér	1352L		Muro	Parete	Parede	Ściana
2	43	1 mm x-veneér	1352L		Muro	Parete	Parede	Ściana
1	44	1 mm x-veneér	1352L		Muro	Parete	Parede	Ściana
1	45	2 mm x-veneér	1344L		Techo	Tetto	Tetto	Dach
1	46	2 mm x-veneér	1344L		Techo	Tetto	Tetto	Dach
1	47	1 mm x-veneér	1352L		Ventana	Finestra	Janela	Okno
2	48	1 mm x-veneér	1352L		Ventana	Finestra	Janela	Okno

Table of contents for YMER Art. No. 244

Pcs.	No.	Dimension	Material	Found in	E	I	P	PL
2	49	1 mm x-veneér	1352L		Ventana	Finestra	Janela	Okno
2	50	1 mm x-veneér	1352L		Ventana	Finestra	Janela	Okno
2	51	1 mm x-veneér	1352L		Ventana	Finestra	Janela	Okno
1	52	1 mm x-veneér	1352L		Revestimiento	Guaina	Revestimiento	Poszycie
4	53	1 mm x-veneér	1352L		Revestimiento	Guaina	Revestimiento	Poszycie
2	54	1 mm x-veneér	1352L		Revestimiento	Guaina	Revestimiento	Poszycie
1	55	1 mm x-veneér	1352L		Revestimiento	Guaina	Revestimiento	Poszycie
2	56	1 mm x-veneér	1352L		Puerta	Porta	Porta	Drzwi
6	57-57b	1 mm x-veneér	1352L		Puerta	Porta	Porta	Drzwi
6	58-58b	1 mm x-veneér	1352L		Lámpara	Lampade	Lâmpada	Lampa
1	59	1 mm x-veneér	1352L		Palo	Albero	Mastro	Maszt
1	60	2 mm x-veneér	1344L		Palo	Albero	Mastro	Maszt
1	61	2 mm x-veneér	1344L		Palo	Albero	Mastro	Maszt
1	62	2 mm x-veneér	1344L		Palo	Albero	Mastro	Maszt
4	63	1 mm x-veneér	1352L		Escalera	Scaletta	Escada	Schody
20	63a-63e	1 mm x-veneér	1352L		Escalera	Scaletta	Escada	Schody
8	64	1 mm x-veneér	1352L		Escalera	Scaletta	Escada	Schody
2	64a	1 mm x-veneér	1352L		Escalera	Scaletta	Escada	Schody
4	65	1 mm x-veneér	1352L		Soporte	Supporto	Suporte	Wspornik
1	66	5x5x300mm	Wood	TS	Base	Base	Base	Podstawa
1	67	ø25x68mm	PVC	TS	Chimenea	Ciminiera	Chaminé	Komin
1	68	ø8x20mm	Wood	TS	Palo redondo	Bastone rotondo	Bastão redondo	Kijek
1	69	ø6x110mm	Wood	TS	Palo redondo	Bastone rotondo	Bastão redondo	Kijek
1	70	ø4x180mm	Wood	TS	Palo	Albero	Mastro	Maszt
4	71	0,7x1x275mm	Wood	TS	Listón	Listello	Tiras	Listwa
1	72	50x30mm	Foil	VEJ	Ventana	Finestra	Janela	Okno
1	73		Flag	VEJ	Bandera	Bandiera	Bandeira	Flaga
1	74		Sticker	VEJ	Calcas	Decalcomania	Decalque	Kalkomania
1	75	100x260mm	Net	VEJ	Red	Rede	Rede	Siatka
1	76	ø2x60mm	Brass	TS	Je de hélice	Albero porta-elica	Eixo da hélice	Wał
1	P25		Plastic		Casco	Scafo	Casco	Kadłub
1	P26		Plastic		Cubierta	Ponte	Convés	Pokład
1		A4		VEJ	Instrucciones de montaje	Istruzioni di montaggio	Instruções de montagem	Instrukcja budowy
1		A3		VEJ	El dibujo	Disegno	Desenho	Rysunek główny
2	F37	15mm	Plastic	FS	Ancla	Ancora	Âncora	Kotwica
2	F39	ø1x250mm	Brass	TS	Hilo de latón	Brasswire	Fio de latão	Drut
1	F45	24,5mm	Plastic	FS	Hélice	Elica	Hélice	Śruba
1	F64/2	5mm	Plastic	FS	Bloques	Bitta	Blocos	Blok
10	F67	ø5mm	Plastic	FS	Portilla	Oblo	Luz de bombordo	Iluminator
1	F71	1m	Rope	TS	Soga	Corda	Corda	Lina
1	F73	1m	Rope	TS	Soga	Corda	Corda	Lina

Table of contents for YMER Art. No. 244

Pcs.	No.	Dimension	Material	Found in	E	I	P	PL
6	F100	ø4x5mm	Brass	FS	Luz	Leggero	Luzes	Lampa
1	F101	5mm	Brass	FS	Reflector	Proiettore	Holofote	Lampa
1	F107	ø6x6mm	Brass	FS	Cabrestante	Argano	Cabrestante	Kabestan
1	F134		Brass	FS	Chigre	Verricello, Arganello	Guincho	Wciagarka
2	F136	ø12mm	Plastic	FS	Cinturones salvavidas	Scialuppa da salvataggio	Bote salv-vida	Koło ratunkowe
1	F158	ø8x8mm	Brass	FS	Cabrestante	Argano	Cabrestante	Kabestan
1	F170	64mm	Plastic	FS	Bote salvavidas	Battello di salvataggio	Barco salva-vidas	Łódź ratunkowa
2	F190	ø3,8mm	Brass	FS	Tubería de halcón	Pipe di Hawse	Hawse Pipe	Kluza
4	F235-4	ø4x6mm	Brass	FS	Casquillo	Boccola	Casquillo	Tuleja
5	F285	6mm	Brass	FS	Perno de cáncamo	Bullone ad occhio	Ferrolho	Śruba
16	F317	ø4x2mm	Plastic	FS	Portilla	Oblò	Luz de bombardeo	Iluminator
1	F327	ø1,5x300mm	Metal	FS	Cadena	Catena	Corrente	Łańcuch
11	F342	10mm	Brass	FS	Plantilla	Parapetto	Amurada	Reling
1	F410	ø2x100mm	Brass	TS	Je de hélice	Albero porta-elica	Eixo da hélice	Wał
1	F662	ø8x10,5mm	Brass	FS	Sirena	Sirena	Sirene	Syrena
2	F911-1	ø3x250mm	Aluminium	FS	Hilo	Wire	Fio	Drut
1	F1011	ø2x60mm	Brass	TS	Eje del timón	Albero di timone	Eixo do leme	Wał



Billing Boats

www.billingboats.com

service@billingboats.dk